

# Area Separation Wall Details

## 1. EXTERIOR WALL INTERSECTION (AS REQUIRED)

### ASSEMBLY U375

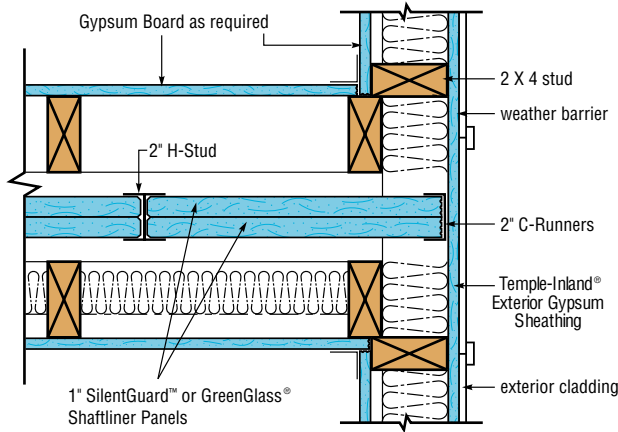

## 2. EXTERIOR WALL INTERSECTION (AS REQUIRED) - VARIATION

### ASSEMBLY U375

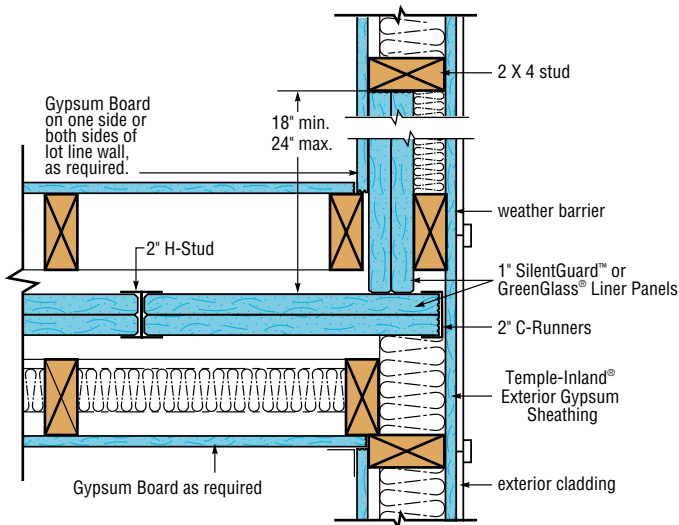

## 3. INTERSECTION AT ROOF

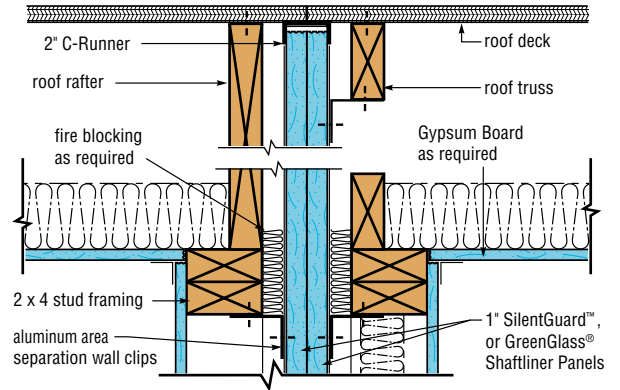

## 4. INTERMEDIATE FLOOR

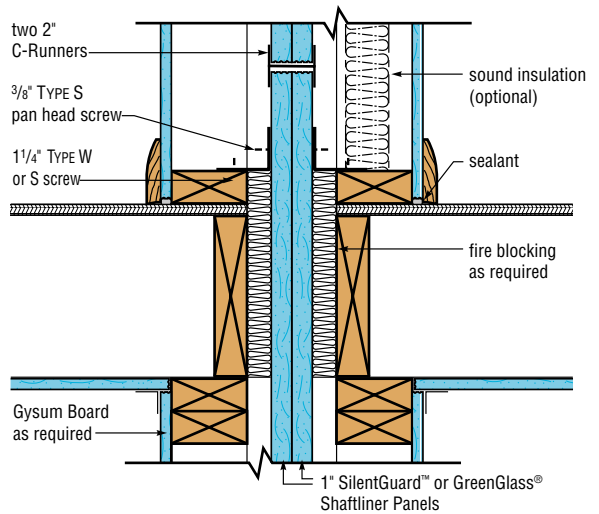

## 5. FOUNDATION

